



TEST REPORT

Test item description: Automatic Pool Cover Control Box
Trademark(s): Landy
Model/Type reference: 2150-DC, 2150-AC, 4500, 9500
Applicant's name: Landy (Guangzhou) Plastic Products Co., Ltd
Address: No. 215 Shipai Industrial Zone, Dongchong Town, Nansha District, Guangzhou, China
Manufacturer: Landy (Guangzhou) Plastic Products Co., Ltd
Address: No. 215 Shipai Industrial Zone, Dongchong Town, Nansha District, Guangzhou, China
Prepared By: Shenzhen CTB Testing Technology Co., Ltd.
Address: 1&2/F., Building A, No.26, Xinghe Road, Xinqiao, Xinqiao Street, Bao'an District, Shenzhen, Guangdong, China
Sample Received Date: Sep. 01, 2025
Sample tested Date: Sep. 01, 2025 to Oct. 14, 2025
Issue Date: Oct. 14, 2025
Report No.: CTB25090108101RF01
Test Standards: ETSI EN 300 220-1 V3.1.1 (2017-02)
ETSI EN 300 220-2 V3.2.1 (2018-06)
Test Results: PASS
Remark: This is SRD radio test report.

Compiled by:

Reviewed by:

Approved by:

Kai Chen

Kai Chen

Martin Feng

Martin Feng



Bin Mei / Director

Note: If there is any objection to the inspection results in this report, please submit a written report to the company within 15 days from the date of receiving the report. The test report is effective only with both signature and specialized stamp. This result(s) shown in this report refer only to the sample(s) tested. Without written approval of Shenzhen CTB Testing Technology Co., Ltd. this report can't be reproduced except in full. The tested sample(s) and the sample information are provided by the client. "★" indicates the testing items were fulfilled by subcontracted lab. "—" indicates the items are not in CNAS accreditation scope.

TABLE OF CONTENT

| Test Report Declaration | Page |
|--|-----------|
| 1. VERSION..... | 4 |
| 2. TEST SUMMARY | 5 |
| 3. MEASUREMENT UNCERTAINTY | 6 |
| 4. PRODUCT INFORMATION AND TEST SETUP | 7 |
| 4.1 Product Information..... | 7 |
| 4.2 Test Setup Configuration..... | 7 |
| 4.3 Support Equipment..... | 7 |
| 4.4 Channel List | 7 |
| 4.5 Test Mode | 8 |
| 4.6 Test Environment..... | 8 |
| 5. TEST FACILITY AND TEST INSTRUMENT USED | 9 |
| 5.1 Test Facility..... | 9 |
| 5.2 Test Instrument Used..... | 9 |
| 6. OPERATING FREQUENCY | 11 |
| 6.1 Block Diagram Of Test Setup..... | 11 |
| 6.2 Limit..... | 11 |
| 6.3 Test procedure | 11 |
| 6.4 Test Result..... | 11 |
| 7. UNWANTED EMISSIONS IN THE SPURIOUS DOMAIN | 12 |
| 7.1 Block Diagram Of Test Setup..... | 12 |
| 7.2 Receiver Setup:..... | 13 |
| 7.3 Limits..... | 13 |
| 7.4 Test Procedure..... | 13 |
| 7.5 Test Results | 15 |
| 8. TX EFFECTIVE RADIATED POWER..... | 16 |
| 8.1 Block Diagram Of Test Setup..... | 16 |
| 8.2 Limits..... | 16 |
| 8.3 Test Procedure..... | 16 |
| 8.4 Test Results | 17 |
| 9. TX DUTY CYCLE | 18 |
| 9.1 Block Diagram Of Test Setup..... | 18 |
| 9.2 Limit..... | 18 |
| 9.3 Test procedure | 18 |
| 9.4 Test Result..... | 18 |
| 10. TX OCCUPIED BANDWIDTH | 19 |
| 10.1 Block Diagram Of Test Setup..... | 19 |
| 10.2 Limit..... | 19 |
| 10.3 Test procedure | 19 |
| 10.4 Test Result..... | 20 |
| 11. TX OUT OF BAND EMISSIONS..... | 21 |
| 11.1 Block Diagram Of Test Setup..... | 21 |
| 11.2 Limit..... | 21 |
| 11.3 Test procedure | 22 |
| 11.4 Test Result..... | 23 |
| 12. TX TRANSIENT..... | 24 |
| 12.1 Block Diagram Of Test Setup..... | 24 |
| 12.2 Limit..... | 24 |
| 12.3 Test procedure | 24 |
| 12.4 Test Result..... | 25 |
| 13. TX BEHAVIOUR UNDER LOW VOLTAGE CONDITIONS | 26 |
| 13.1 Block Diagram Of Test Setup..... | 26 |
| 13.2 Limit..... | 26 |
| 13.3 Test procedure | 26 |

| | | |
|------------|--|-----------|
| 13.4 | Test Result..... | 27 |
| 14. | RX BLOCKING..... | 28 |
| 14.1 | Block Diagram Of Test Setup..... | 28 |
| 14.2 | Limit..... | 28 |
| 14.3 | Test procedure..... | 29 |
| 14.4 | Test Result..... | 30 |
| 15. | EUT PHOTOGRAPHS..... | 31 |
| 16. | EUT TEST SETUP PHOTOGRAPHS..... | 32 |

(Note: N/A means not applicable)

1. VERSION

| Report No. | Issue Date | Description | Approved |
|--------------------|---------------|-------------|----------|
| CTB25090108101RF01 | Oct. 14, 2025 | Original | Valid |

2. TEST SUMMARY

The Product has been tested according to the following specifications:

| Test Item | Test Requirement Clause (EN 300 220-2) | Test Method Clause (EN 300 220-1) | Results |
|---|--|-----------------------------------|---------|
| Transmitter Parameters | | | |
| Operating frequency | Clause 4.2.1 | Clause 5.1 | PASS |
| Unwanted emissions in the spurious domain | Clause 4.2.2 | Clause 5.9 | PASS |
| TX effective radiated power | Clause 4.3.1 | Clause 5.2 | PASS |
| TX Maximum e.r.p. spectral density | Clause 4.3.2 | Clause 5.3 | N/A1 |
| TX Duty cycle | Clause 4.3.3 | Clause 5.4 | PASS |
| TX Occupied bandwidth | Clause 4.3.4 | Clause 5.6 | PASS |
| TX out of band emissions | Clause 4.3.5 | Clause 5.8 | PASS |
| TX Transient | Clause 4.3.6 | Clause 5.10 | PASS |
| TX Adjacent channel power | Clause 4.3.7 | Clause 5.11 | N/A2 |
| TX behaviour under low voltage conditions | Clause 4.3.8 | Clause 5.12 | PASS |
| TX Adaptive power control | Clause 4.3.9 | Clause 5.13 | N/A3 |
| TX FHSS | Clause 4.3.10 | N/A | N/A4 |
| TX Short term behaviour | Clause 4.3.11 | Clause 5.5 | N/A5 |
| Receiver Parameters | | | |
| RX sensitivity | Clause 4.4.1 | Clause 5.14 | N/A6 |
| RX Blocking | Clause 4.4.2 | Clause 5.18 | PASS |
| Polite spectrum access conformance requirement | | | |
| Clear channel assessment threshold | Clause 4.5.2 | Clause 5.21.2 | N/A7 |
| Polite spectrum access timing parameters | Clause 4.5.3 | Clause 5.21.3 | N/A7 |
| Adaptive Frequency Agility | Clause 4.5.4 | Clause 5.21.4 | N/A8 |
| N/A1: Applies to EUT using annex B band I. Applies to EUT using DSSS or wideband techniques other than FHSS modulation, using annex C band W, AA or AC. N/A2: Applies to EUT with $OCW \leq 25$ kHz. N/A3: Applies to EUT with adaptive power control using annex C band AF. N/A4: Applies to FHSS EUT using the band 863 MHz to 870 MHz. N/A5: Applies to EUT using annex C bands AD, AE, AF, AG, AH, or AI. N/A6: Applies to EUT employing polite spectrum access. N/A7: Applies to EUT employing polite spectrum access. N/A8: Applies to EUT with AFA. | | | |

3. MEASUREMENT UNCERTAINTY

Where relevant, the following measurement uncertainty levels have been estimated for tests performed on the Product as specified in CISPR 16-4-2. This uncertainty represents an expanded uncertainty expressed at approximately the 95% confidence level using a coverage factor of k=2.

| Item | Uncertainty |
|--|--------------------|
| Occupancy bandwidth | 54.3kHz |
| Conducted output power above 1G | 0.9dB |
| Conducted output power below 1G | 0.9dB |
| Power Spectral Density, Conduction | 0.9dB |
| Conduction spurious emissions | 2.0dB |
| Out of band emission | 2.0dB |
| 3m chamber Radiated spurious emission(30MHz-1GHz) | 4.6dB |
| 3m chamber Radiated spurious emission(1GHz-18GHz) | 5.1dB |
| 3m chamber Radiated spurious emission(18GHz-40GHz) | 3.4dB |
| Receiver Reference Sensitivity level | 1.9dB |
| Humidity uncertainty | 5.5% |
| Temperature uncertainty | 0.63°C |
| Frequency | 1×10 ⁻⁷ |

4. PRODUCT INFORMATION AND TEST SETUP

4.1 Product Information

Model/Type reference: 2150-DC, 2150-AC, 4500, 9500

Model Difference: All the model are the same circuit and RF module, only the name is different. Test sample model: 2150-DC

SRD: 434.05MHz

Receiver Category: 2

Hardware Version: V1.0

Software Version: V1.0

Max. RF output power: 5.26dBm

Type of Modulation: FSK

Antenna installation: Telescopic Antenna

Ratings: Control Box: INPUT: 110~240Vac 50/60Hz 2.68A 350w
OUTPUT: 25VDC 14A
Remote Control: DC 12V~23A by battery

4.2 Test Setup Configuration

See test photographs attached in EUT TEST SETUP Photographs for the actual connections between Product and support equipment.

4.3 Support Equipment

| Item | Equipment | Mfr/Brand | Model/Type No. | Series No. | Note |
|------|-----------|-----------|----------------|------------|------|
| / | / | / | / | / | / |

Notes:

1. All the equipment/cables were placed in the worst-case configuration to maximize the emission during the test.
2. Grounding was established in accordance with the manufacturer's requirements and conditions for the intended use.

4.4 Channel List

N/A

4.5 Test Mode

All test mode(s) and condition(s) mentioned were considered and evaluated respectively by performing full tests, the worst data were recorded and reported.

| Test mode | Low channel | Middle channel | High channel |
|--------------|-------------|----------------|--------------|
| Transmitting | / | 433.923MHz | / |
| Receiving | / | 433.923MHz | / |

4.6 Test Environment

| | |
|----------------------------|------|
| Humidity(%): | 54 |
| Atmospheric Pressure(kPa): | 101 |
| Normal Voltage(DC)(V): | 12 |
| Low Voltage(DC)(V): | 10.8 |
| High Voltage(DC)(V): | 13.2 |
| Normal Temperature(°C) : | 23 |
| Low Temperature(°C) : | -10 |
| High Temperature(°C) : | 40 |

5. Test Facility and test Instrument Used

5.1 Test Facility

All measurement facilities used to collect the measurement data are located at 1&2F., Building A, No. 26, Xinhe Road, Xinqiao, Xinqiao Street, Bao'an District, Shenzhen, Guangdong, China. The site and apparatus are constructed in conformance with the requirements of ANSI C63.4 and CISPR 16-1-1 other equivalent standards.

5.2 Test Instrument Used

RF conduction and Radiation Test equipment

| No. | Equipment | Manufacturer | Type No. | Serial No. | Firmware Version | Calibrated Date | Calibrated until |
|-----|---|--------------|---------------------------|--------------|------------------------------|-----------------|------------------|
| 1 | Spectrum Analyzer | Agilent | N9020A | MY52090073 | A.14.16 | 2025/5/23 | 2026/5/22 |
| 2 | Power Sensor | Agilent | U2021XA | MY56120032 | / | 2025/5/23 | 2026/5/22 |
| 3 | Power Sensor | Agilent | U2021XA | MY56120034 | / | 2025/5/23 | 2026/5/22 |
| 4 | Communication test set | R&S | CMW500 | 108058 | V3.5.80 | 2025/5/23 | 2026/5/22 |
| 5 | Spectrum Analyzer | KEYSIGHT | N9020A | MY51289897 | A.14.16 | 2025/5/23 | 2026/5/22 |
| 6 | Signal Generator | Agilent | N5181A | MY50140365 | A.01.60 | 2025/5/22 | 2026/5/21 |
| 7 | Vector signal generator | Agilent | N5182A | MY47420195 | A.01.87 | 2025/5/22 | 2026/5/21 |
| 8 | Communication test set | Agilent | E5515C | MY50102567 | B.19.07 (E1962B) | 2025/5/22 | 2026/5/21 |
| 9 | 2.4 GHz Filter | Shenxiang | MSF2400-24 83.5MS-1154 | 20181015001 | / | 2025/6/18 | 2026/6/17 |
| 10 | 5 GHz Filter | Shenxiang | MSF5150-58 50MS-1155 | 20181015001 | / | 2025/6/18 | 2026/6/17 |
| 11 | Filter | Xingbo | XBLBQ-DZA 120 | 190821-1-1 | / | 2025/5/24 | 2026/5/23 |
| 12 | BT&WI-FI Automatic test software | Microwave | MTS8310 | Ver. 2.0.0.0 | / | / | / |
| 13 | Rohde & Schwarz SFU Broadcast Test System | R&S | SFU | 101017 | / | 2024/10/3 1 | 2025/10/30 |
| 14 | Temperature humidity chamber | Hongjing | TH-80CH | DG-15174 | / | 2025/5/22 | 2026/5/21 |
| 15 | 234G Automatic test software | Microwave | MTS8200 | Ver. 2.0.0.0 | / | / | / |
| 16 | 966 chamber | C.R.T. | 966 | / | / | 2024/6/23 | 2027/6/22 |
| 17 | Receiver | R&S | ESPI | 100362 | RF_ATTEN_7 (104489/003) | 2025/5/23 | 2026/5/22 |
| 18 | Amplifier | HP | 8447E | 2945A02747 | / | 2025/5/23 | 2026/5/22 |

| | | | | | | | |
|----|--|-------------|------------|------------|---------|-----------|-----------|
| 19 | Amplifier | Agilent | 8449B | 3008A01838 | / | 2025/6/2 | 2026/6/1 |
| 20 | TRILOG Broadband Antenna | Schwarzbeck | VULB 9168 | 00869 | / | 2025/6/29 | 2026/6/28 |
| 21 | Double Ridged Broadband Horn Antenna | Schwarzbeck | BBHA9120D | 01911 | / | 2025/6/1 | 2026/5/31 |
| 22 | EMI test software | Fala | EZ-EMC | FA-03A2 RE | / | / | / |
| 23 | Loop Antenna | Schwarzbeck | FMZB 1519B | 1519B-224 | / | 2025/6/2 | 2026/6/1 |
| 24 | loop antenna | ZHINAN | ZN30900A | GTS534 | / | / | / |
| 25 | 40G Horn antenna | A/H/System | SAS-574 | 588 | / | 2025/6/2 | 2026/6/1 |
| 26 | Amplifier | AEROFLEX | Aeroflex | 097 | / | 2025/6/2 | 2026/6/1 |
| 27 | Power Meter | KEYSIGHT | N1912AP | N/A | A.05.00 | 2025/6/2 | 2026/6/1 |

6. Operating frequency

6.1 Block Diagram Of Test Setup

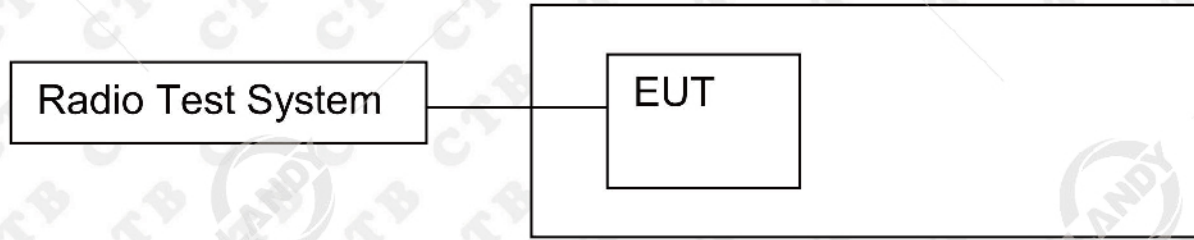

6.2 Limit

Short Range Devices frequency ranges: 433,040 MHz to 434,790 MHz

6.3 Test procedure

N/A

6.4 Test Result

| Value | Notes |
|--|--------------------|
| Operational Frequency band or bands | 433.050-434.790MHz |
| Nominal Operating Frequency or Frequencies | 434.05MHz |
| Operating Channel width(s) - OCW | 45.627kHz |
| Note: Declared by the manufacturer | |

7. UNWANTED EMISSIONS IN THE SPURIOUS DOMAIN

7.1 Block Diagram Of Test Setup

(A) Radiated Emission Test Set-Up, Frequency Below 1000MHz

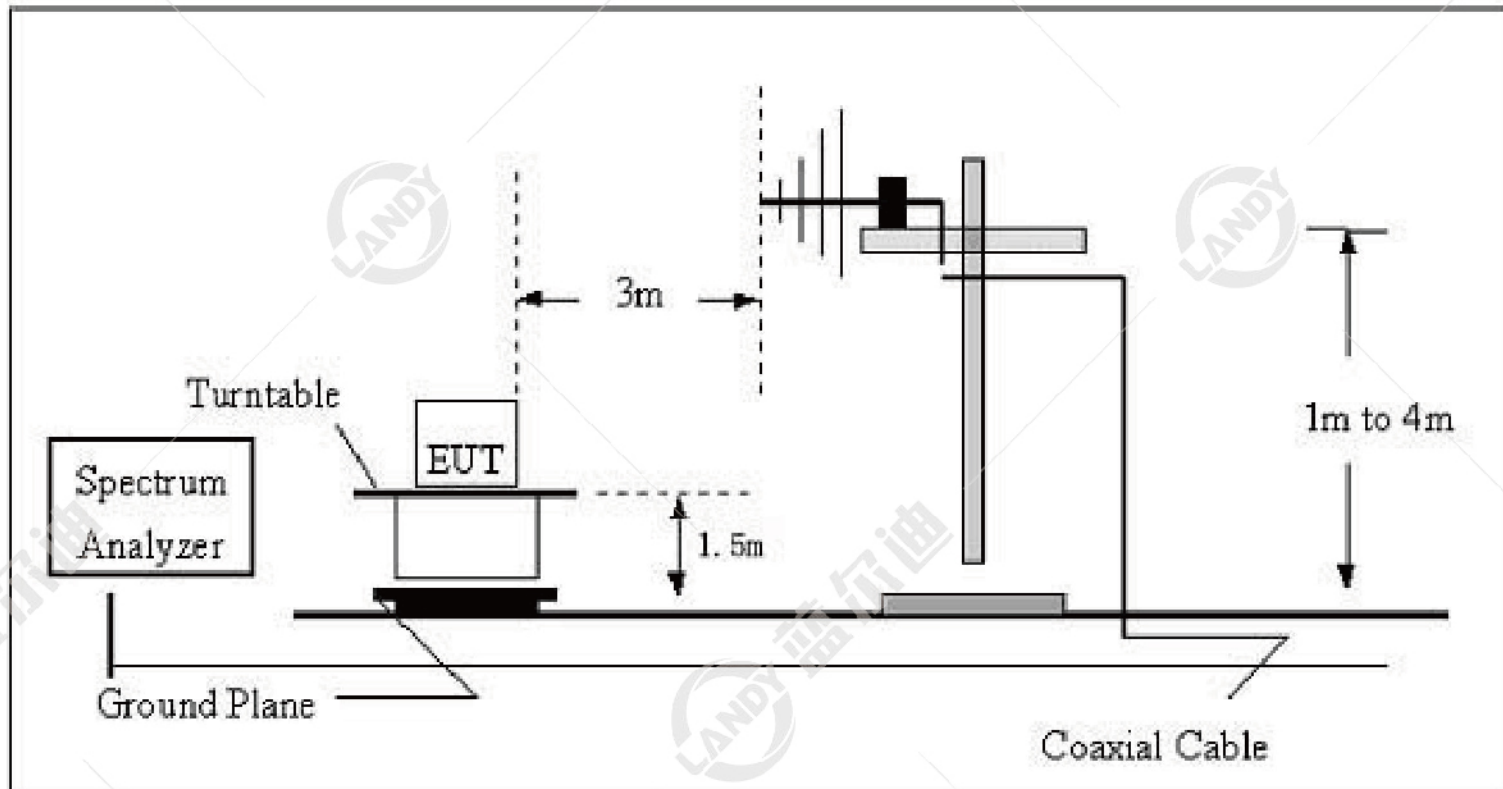

(B) Radiated Emission Test Set-Up Frequency Above 1 GHz

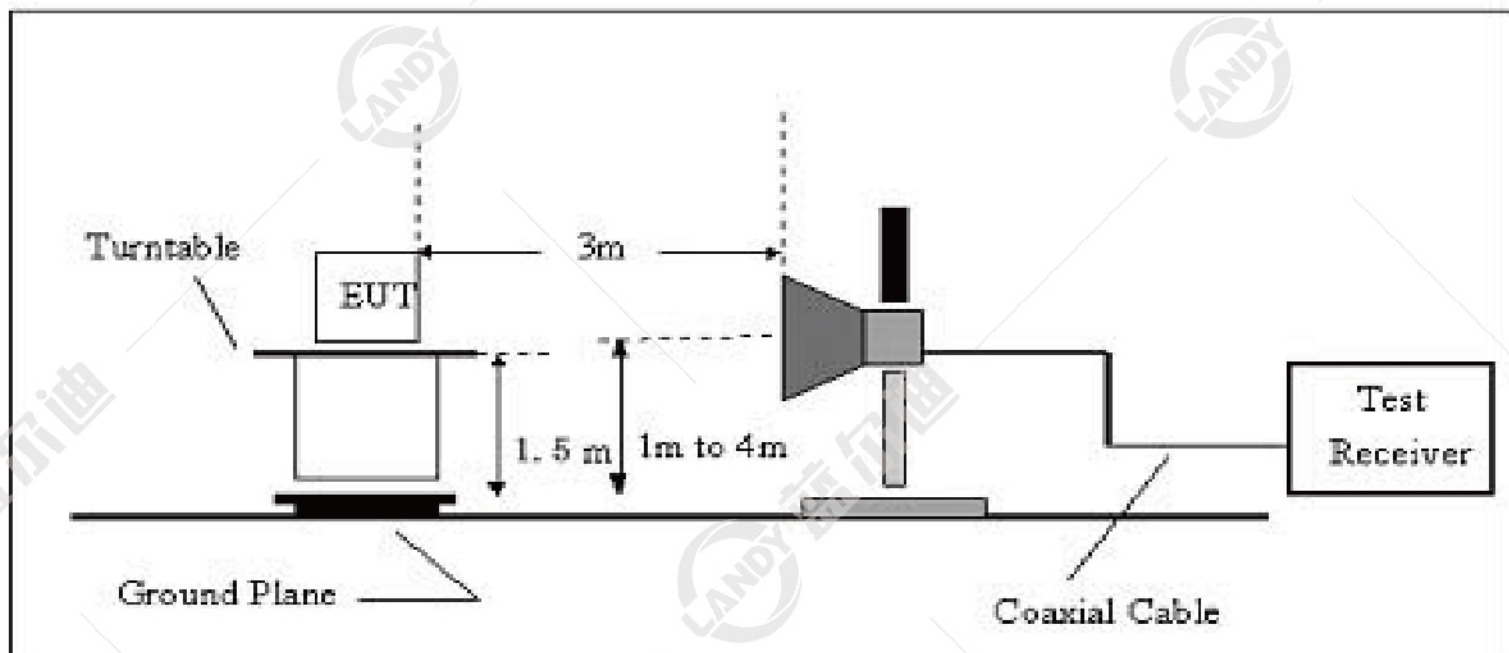

7.2 Receiver Setup:

| Operating Mode | Frequency Range | RBW _{REF} (see note 2) | VBW | Detector mode |
|----------------|---|---------------------------------|------|---------------|
| Transmit mode | $9 \text{ kHz} \leq f < 150 \text{ kHz}$ | 1 kHz | 3RBW | Peak |
| | $150 \text{ kHz} \leq f < 30 \text{ MHz}$ | 10 kHz | 3RBW | Peak |
| | $30 \text{ MHz} \leq f < f_c - m$ | 100 kHz | 3RBW | Peak |
| | $f_c - m \leq f < f_c - n$ | 10 kHz | 3RBW | Peak |
| | $f_c - n \leq f < f_c - p$ | 1 kHz | 3RBW | Peak |
| | $f_c + p < f \leq f_c + n$ | 1 kHz | 3RBW | Peak |
| | $f_c + n < f \leq f_c + m$ | 10 kHz | 3RBW | Peak |
| | $f_c + m < f \leq 1 \text{ GHz}$ | 100 kHz | 3RBW | Peak |
| | $1 \text{ GHz} < f \leq 6 \text{ GHz}$ | 1 MHz | 3RBW | Peak |

NOTE 1: f is the measurement frequency.

f_c is the Operating Frequency.

m is 10 x OCW or 500 kHz, whichever is the greater.

n is 4 x OCW or 100 kHz, whichever is the greater.

p is 2,5 x OCW.

NOTE 2: If the value of RBW used for measurement is different from RBW_{REF} use bandwidth correction from EN 300 220-1 V3.1.1 (2017-02) clause 4.3.10.1.

7.3 Limits

| Frequency range | Maximum power, e.r.p. ($\leq 1 \text{ GHz}$) e.i.r.p. ($> 1 \text{ GHz}$) | RBW/VBW |
|---------------------|---|----------------|
| 30 MHz to 47 MHz | -36 dBm | 100 kHz/300KHz |
| 47 MHz to 74 MHz | -54 dBm | 100 kHz/300KHz |
| 74 MHz to 87,5 MHz | -36 dBm | 100 kHz/300KHz |
| 87,5 MHz to 118 MHz | -54 dBm | 100 kHz/300KHz |
| 118 MHz to 174 MHz | -36 dBm | 100 kHz/300KHz |
| 174 MHz to 230 MHz | -54 dBm | 100 kHz/300KHz |
| 230 MHz to 470 MHz | -36 dBm | 100 kHz/300KHz |
| 470 MHz to 862 MHz | -54 dBm | 100 kHz/300KHz |
| 862 MHz to 1 GHz | -36 dBm | 100 kHz/300KHz |
| 1 GHz to 12,75 GHz | -30 dBm | 1 MHz/3MHz |

7.4 Test Procedure

1. Scan from 25MHz to 6GHz, find the maximum radiation frequency to measure.
2. The technique used to find the Spurious Emissions of the transmitter was the antenna substitution method. Substitution method was performed to determine the actual ERP/EIRP emission levels of the EUT.

Test procedure as below:

- 1) The EUT was powered ON and placed on a 1.5m high table at a 3 meter fully Anechoic Chamber. The antenna of the transmitter was extended to its maximum length. modulation mode and the measuring receiver shall be tuned to the frequency of the transmitter under test.
- 2) The EUT was set 3 meters (above 18GHz the distance is 1 meter) away from the interference-receiving antenna, which was mounted on the top of a variable-height antenna tower.
- 3) The disturbance of the transmitter was maximized on the test receiver display by raising and lowering from 1m to 4m the receive antenna and by rotating through 360° the turntable. After the fundamental emission was maximized, a field strength measurement was made.
- 4) Steps 1) to 3) were performed with the EUT and the receive antenna in both vertical and horizontal polarization.
- 5) The transmitter was then removed and replaced with another antenna. The center of the antenna was approximately at the same location as the center of the transmitter.
- 6) A signal at the disturbance was fed to the substitution antenna by means of a non-radiating cable. With both the substitution and the receive antennas horizontally polarized, the receive antenna was raised and

lowered to obtain a maximum reading at the test receiver. The level of the signal generator was adjusted until the measured field strength level in step 3) is obtained for this set of conditions.

- 7) The output power into the substitution antenna was then measured.
- 8) Steps 6) and 7) were repeated with both antennas polarized.
- 9) Calculate power in dBm by the following formula:

$$\text{ERP(dBm)} = P_{\text{SG}} (\text{dBm}) - \text{cable loss (dB)} + \text{antenna gain (dBd)}$$

$$\text{EIRP(dBm)} = P_{\text{SG}} (\text{dBm}) - \text{cable loss (dB)} + \text{antenna gain (dBi)}$$

$$\text{EIRP} = \text{ERP} + 2\text{dB}$$

where: P_g is the generator output power into the substitution antenna.

- 10) Test the EUT in the lowest channel, middle channel, the Highest channel
Repeat above procedures until all frequencies measured was complete..

7.5 Test Results

Below 1GHz

| Freq (MHz) | Rd_level (dBm) | Factor (dB) | Level (dBm) | Limit (dBm) | Over (dB) | detector | Height | Degree | Antenna polarization |
|------------|----------------|-------------|-------------|-------------|-----------|----------|--------|--------|----------------------|
| 46.151 | -54.95 | -11.87 | -66.81 | -36.00 | -30.81 | peak | 1.1 | 163 | H |
| 67.587 | -54.85 | -12.56 | -67.41 | -54.00 | -13.41 | peak | 1.7 | 29 | H |
| 103.501 | -55.74 | -12.02 | -67.76 | -54.00 | -13.76 | peak | 1.6 | 274 | H |
| 218.544 | -52.90 | -11.24 | -64.13 | -54.00 | -10.13 | peak | 1.6 | 277 | H |
| 327.844 | -52.95 | -10.26 | -63.22 | -36.00 | -27.22 | peak | 1.8 | 112 | H |
| 871.596 | -52.07 | 0.02 | -52.05 | -36.00 | -16.05 | peak | 1.3 | 348 | H |
| 47.755 | -55.36 | -12.57 | -67.93 | -36.00 | -31.93 | peak | 1.7 | 158 | V |
| 102.217 | -54.92 | -11.96 | -66.88 | -54.00 | -12.88 | peak | 1.2 | 293 | V |
| 184.895 | -56.25 | -12.33 | -68.59 | -54.00 | -14.59 | peak | 1.1 | 19 | V |
| 219.541 | -52.82 | -10.42 | -63.24 | -54.00 | -9.24 | peak | 1.7 | 270 | V |
| 328.583 | -52.88 | -9.68 | -62.56 | -36.00 | -26.56 | peak | 1.7 | 269 | V |
| 871.326 | -52.60 | -0.35 | -52.95 | -36.00 | -16.95 | peak | 1.3 | 289 | V |

Above 1GHz

| Freq (MHz) | Rd_level (dBm) | Factor (dB) | Level (dBm) | Limit (dBm) | Over (dB) | detector | Height | Degree | Antenna polarization |
|------------|----------------|-------------|-------------|-------------|-----------|----------|--------|--------|----------------------|
| 1300.134 | -55.23 | -0.47 | -55.69 | -30.00 | -25.69 | peak | 1.8 | 28 | H |
| 2168.109 | -54.74 | 3.09 | -51.65 | -30.00 | -21.65 | peak | 1.1 | 262 | H |
| 3637.181 | -55.55 | 5.62 | -49.93 | -30.00 | -19.93 | peak | 1.3 | 271 | H |
| 4763.412 | -53.46 | 8.78 | -44.68 | -30.00 | -14.68 | peak | 1.9 | 285 | H |
| 5973.778 | -53.38 | 11.87 | -41.51 | -30.00 | -11.51 | peak | 1.7 | 86 | H |
| 7247.774 | -52.61 | 12.58 | -40.03 | -30.00 | -10.03 | peak | 1.5 | 247 | H |
| 1301.638 | -55.15 | -1.08 | -56.23 | -30.00 | -26.23 | peak | 1.3 | 27 | V |
| 1735.612 | -54.85 | -0.03 | -54.88 | -30.00 | -24.88 | peak | 1.5 | 269 | V |
| 2169.030 | -55.54 | 3.27 | -52.27 | -30.00 | -22.27 | peak | 1.5 | 267 | V |
| 2900.173 | -53.05 | 4.02 | -49.03 | -30.00 | -19.03 | peak | 1.7 | 287 | V |
| 4258.145 | -52.72 | 8.81 | -43.90 | -30.00 | -13.90 | peak | 1.7 | 85 | V |
| 5942.048 | -52.36 | 11.76 | -40.59 | -30.00 | -10.59 | peak | 1.9 | 249 | V |

8. TX EFFECTIVE RADIATED POWER

8.1 Block Diagram Of Test Setup

(A) Radiated Emission Test Set-Up, Frequency Below 1000MHz

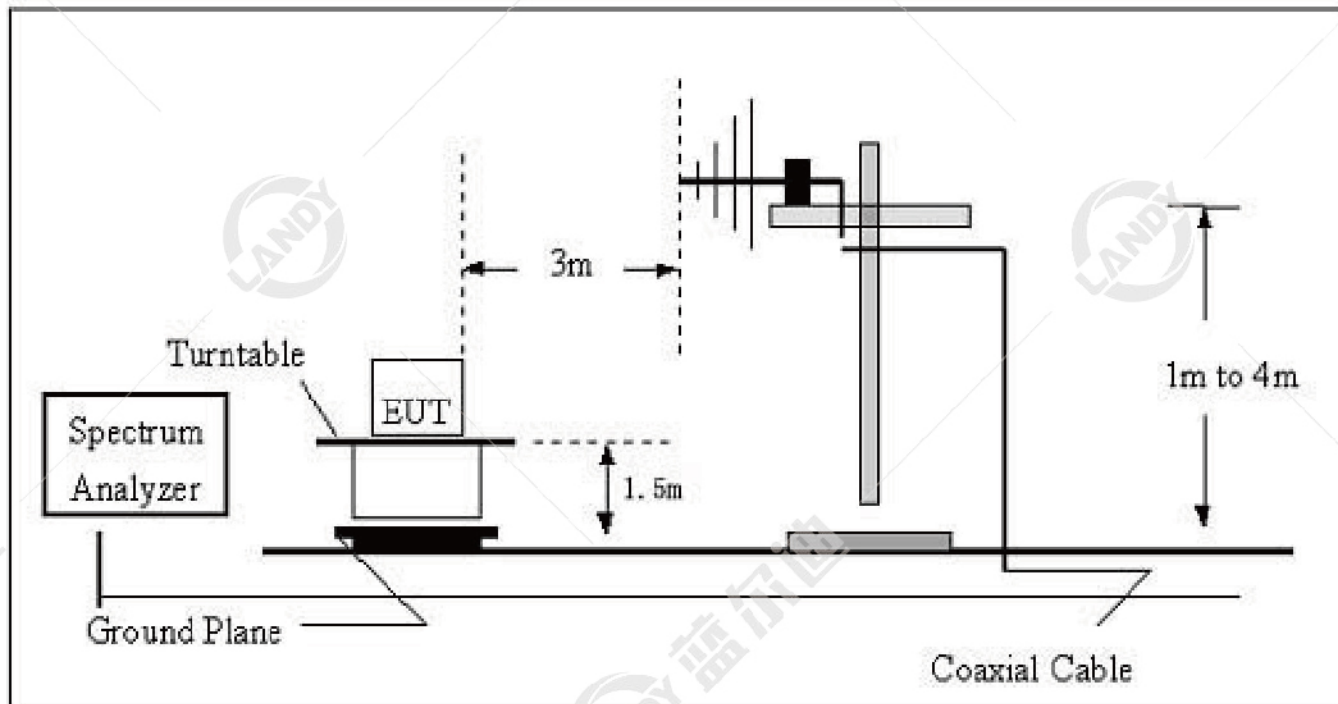

8.2 Limits

| Frequency(MHz) | Limit(ERP,mW) |
|----------------|---------------|
| 433.92 | 10 |
| 868.40 | 25 |

8.3 Test Procedure

- 1) The EUT was powered ON and placed on a 1.5m high table at a 3 meter fully Anechoic Chamber. The antenna of the transmitter was extended to its maximum length. Modulation mode and the measuring receiver shall be tuned to the frequency of the transmitter under test.
- 2) The EUT was set 3 meters away from the interference-receiving antenna, which was mounted on the top of a variable-height antenna tower.
- 3) The disturbance of the transmitter was maximized on the test receiver display by raising and lowering from 1m to 4m the receive antenna and by rotating through 360° the turntable. After the fundamental emission was maximized, a field strength measurement was made.
- 4) Steps 1) to 3) were performed with the EUT and the receive antenna in both vertical and horizontal polarization.
- 5) The transmitter was then removed and replaced with another antenna. The center of the antenna was approximately at the same location as the center of the transmitter.
- 6) A signal at the disturbance was fed to the substitution antenna by means of a non-radiating cable. With both the substitution and the receive antennas horizontally polarized, the receive antenna was raised and lowered to obtain a maximum reading at the test receiver. The level of the signal generator was adjusted until the measured field strength level in step 3) is obtained for this set of conditions.
- 7) The output power into the substitution antenna was then measured.
- 8) Steps 6) and 7) were repeated with both antennas polarized.
- 9) Calculate power in dBm by the following formula:

$$ERP(dBm) = P_{SG} (dBm) - \text{cable loss} (dB) + \text{antenna gain} (dBd)$$
 Where: P_{SG} is the generator output power into the substitution antenna.
- 10) Test the EUT in the lowest channel ,middle channel, the Highest channel

8.4 Test Results

| Measurement Conditions | | Operation Frequency (MHz) | ERP (dBm) | Limit (dBm) | Result |
|------------------------|---------|----------------------------|-----------|-------------|--------|
| Temperature | Voltage | | | | |
| Normal | Normal | 434.050 | 5.26 | 10 | PASS |
| High | High | 434.050 | 5.22 | 10 | PASS |
| | Low | 434.050 | 5.18 | 10 | PASS |
| Low | High | 434.050 | 5.24 | 10 | PASS |
| | Low | 434.050 | 5.14 | 10 | PASS |

9. TX DUTY CYCLE

9.1 Block Diagram Of Test Setup

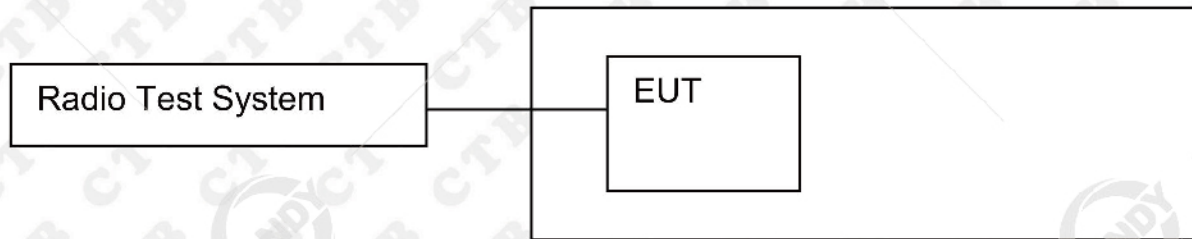

9.2 Limit

Limit: 10%

9.3 Test procedure

Duty cycle is the ratio expressed as a percentage, of the cumulative duration of transmissions T_{on_cum} within an observation interval T_{obs} . $DC = (T_{on_cum} / T_{obs}) F_{obs}$.

on an observation bandwidth F_{obs} .

Unless otherwise specified, T_{obs} is 1 hour and the observation bandwidth F_{obs} is the operational frequency band.

Each transmission consists of an RF emission, or sequence of RF emissions separated by intervals $< T_{Dis}$.

9.4 Test Result

The duty cycle was not exceeded 10% in a period of 1 hour, which was declared by the manufacturer

10. TX OCCUPIED BANDWIDTH

10.1 Block Diagram Of Test Setup

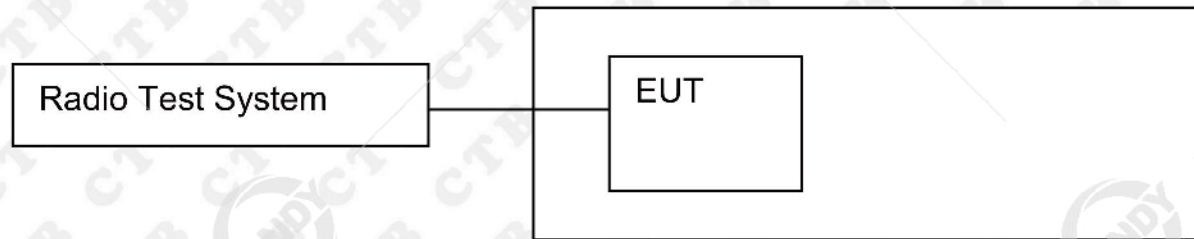

10.2 Limit

The Operating Channel shall be declared and shall reside entirely within the Operational Frequency Band. The Maximum Occupied Bandwidth at 99 % shall reside entirely within the Operating Channel defined by F_{low} and F_{high} .

10.3 Test procedure

| Setting | Value | Notes |
|------------------|--|--|
| Centre frequency | The nominal Operating Frequency | The highest or lowest Operating Frequency as declared by the manufacturer |
| RBW | 1 % to 3 % of OCW without being below 100 Hz | |
| VBW | 3 x RBW | Nearest available analyser setting to 3 x RBW |
| Span | At least 2 x Operating Channel width | Span should be large enough to include all major components of the signal and its side bands |
| Detector Mode | RMS | |
| Trace | Max hold | |

Step 1:

Operation of the EUT shall be started, on the highest operating frequency as declared by the manufacturer, with the appropriate test signal.

The signal attenuation shall be adjusted to ensure that the signal power envelope is sufficiently above the noise floor of the analyser to avoid the noise signals on either side of the power envelope being included in the measurement.

Step 2:

When the trace is completed the peak value of the trace shall be located and the analyser marker placed on this peak.

Step 3:

The 99 % occupied bandwidth function of the spectrum analyser shall be used to measure the occupied bandwidth of the signal.

10.4 Test Result

| Measurement Conditions | | Operation Frequency (MHz) | OBW (kHz) | Result |
|------------------------|---------|---------------------------|-----------|--------|
| Temperature | Voltage | | | |
| Normal | Normal | 434.050 | 45.627 | PASS |
| High | High | 434.050 | 45.614 | PASS |
| | Low | 434.050 | 45.618 | PASS |
| Low | High | 434.050 | 45.618 | PASS |
| | Low | 434.050 | 45.612 | PASS |

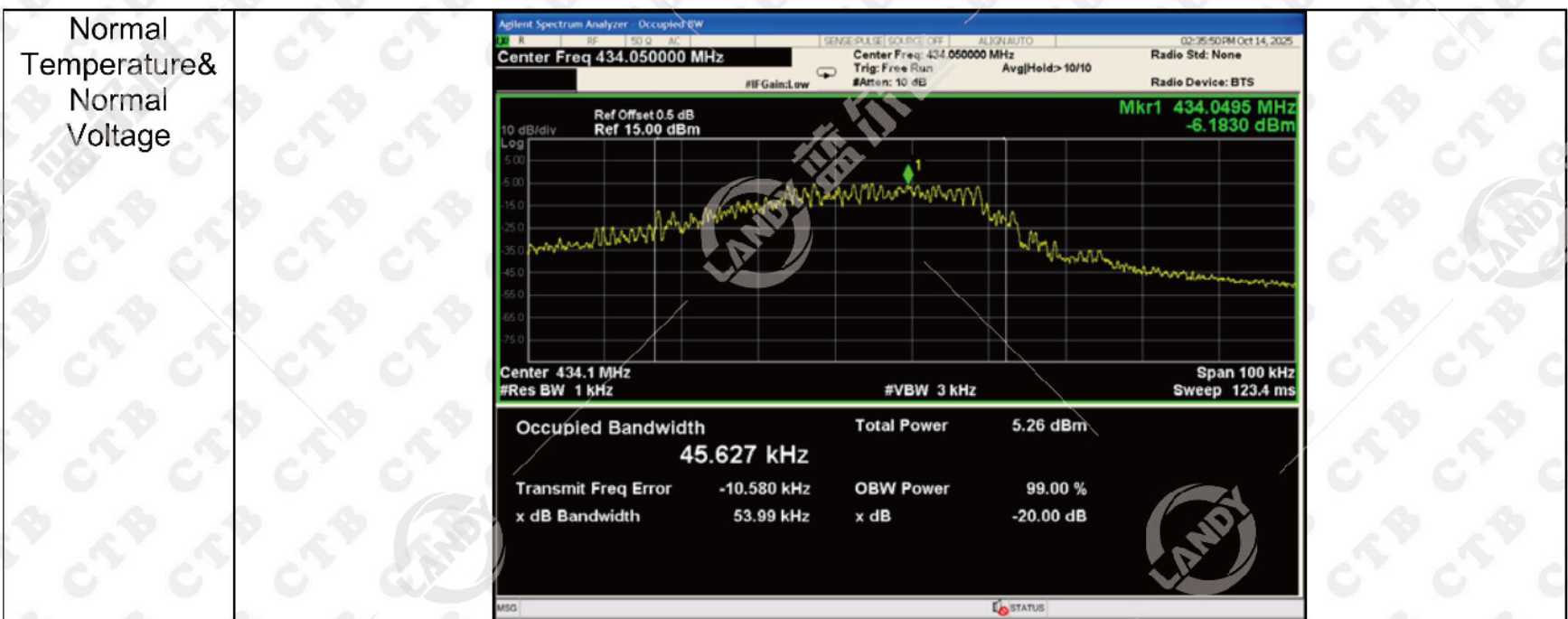

Remark: This Report only show the test plots of the worst case.

11. TX OUT OF BAND EMISSIONS

11.1 Block Diagram Of Test Setup

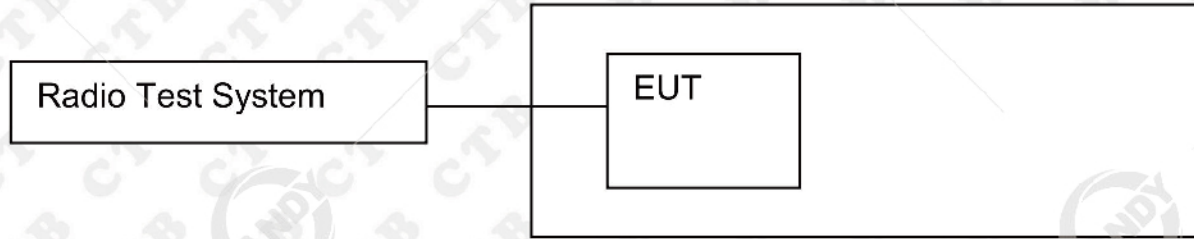

11.2 Limit

| Domain | Frequency Range | RBW _{REF} | Max power limit |
|--|---|--------------------|-----------------|
| OOB limits applicable to Operational Frequency Band (See Figure 6) | $f \leq f_{low_OFB} - 400\text{ kHz}$ | 10 kHz | -36 dBm |
| | $f_{low_OFB} - 400\text{ kHz} \leq f \leq f_{low_OFB} - 200\text{ kHz}$ | 1 kHz | -36 dBm |
| | $f_{low} - 200\text{ kHz} \leq f < f_{low_OFB}$ | 1 kHz | See Figure 6 |
| | $f = f_{low_OFB}$ | 1 kHz | 0 dBm |
| | $f = f_{high_OFB}$ | 1 kHz | 0 dBm |
| | $f_{high_OFB} < f \leq f_{high_OFB} + 200\text{ kHz}$ | 1 kHz | See Figure 6 |
| | $f_{high_OFB} + 200\text{ kHz} \leq f \leq f_{high_OFB} + 400\text{ kHz}$ | 1 kHz | -36 dBm |
| OOB limits applicable to Operating Channel (See Figure 5) | $f_{high_OFB} + 400\text{ kHz} \leq f$ | 10 kHz | -36 dBm |
| | $f = f_c - 2.5 \times \text{OCW}$ | 1 kHz | -36 dBm |
| | $f_c - 2.5 \times \text{OCW} \leq f \leq f_c - 0.5 \times \text{OCW}$ | 1 kHz | See Figure 5 |
| | $f = f_c - 0.5 \times \text{OCW}$ | 1 kHz | 0 dBm |
| | $f = f_c + 0.5 \times \text{OCW}$ | 1 kHz | 0 dBm |
| | $f_c + 0.5 \times \text{OCW} \leq f \leq f_c + 2.5 \times \text{OCW}$ | 1 kHz | See Figure 5 |
| | $f = f_c + 2.5 \times \text{OCW}$ | 1 kHz | -36 dBm |

NOTE: f is the measurement frequency.
 f_c is the Operating Frequency.
 f_{low_OFB} is the lower edge of the Operational Frequency Band.
 f_{high_OFB} is the upper edge of the Operational Frequency Band.
 OCW is the operating channel bandwidth.

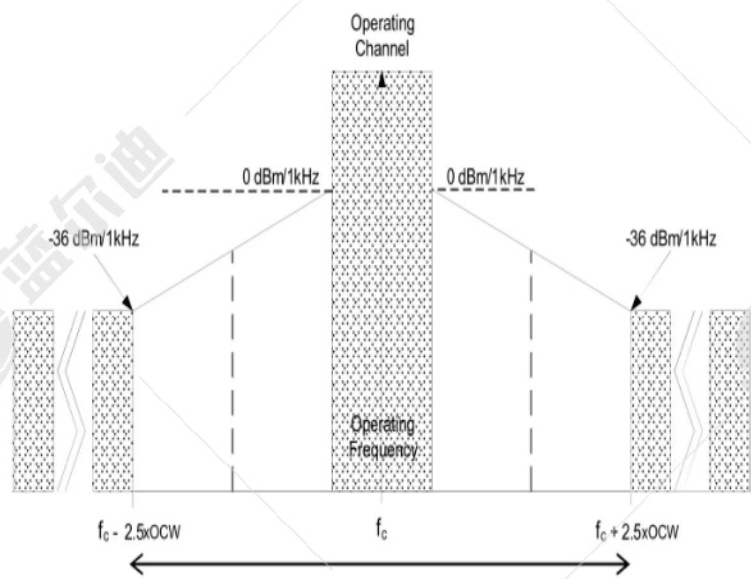

Figure 5: Out Of Band Domain for Operating Channel with reference BW

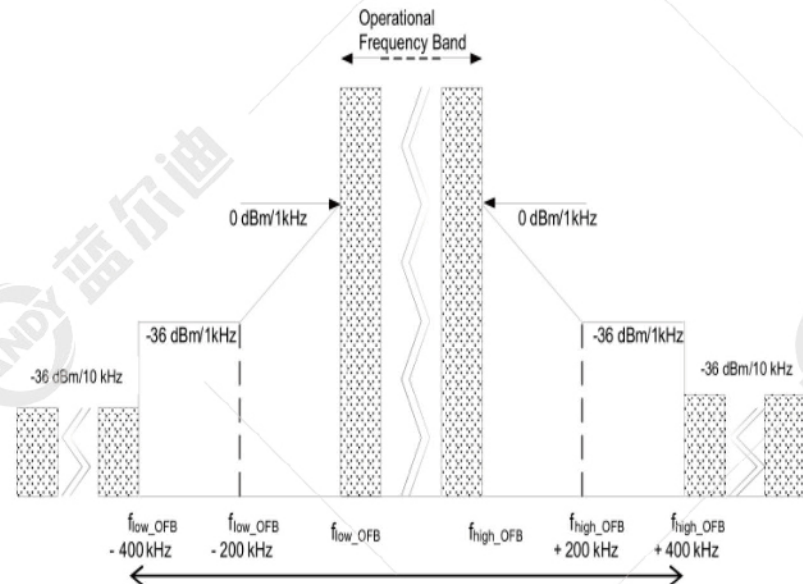

Figure 6: Out Of Band Domain for Operational Frequency Band with reference BW

11.3 Test procedure

| Spectrum Analyser Setting | Value | Notes |
|--|-----------------------------|--|
| Centre frequency | Operating Frequency | |
| Span | 6 x Operating Channel width | |
| RBW | 1 kHz (see note) | Resolution bandwidth for Out Of Band domain measurements |
| Detector Function | RMS | |
| Trace Mode | Linear AVG | Applies only for EUT generating D-M2 test signal. An appropriate number of samples should be averaged to give a stable reading |
| | Max Hold | Applies only for EUT generating D-M2a or D-M3 test signal. |
| NOTE: If the value of RBW used is different from RBW_{REF} in clause 5.8.2, use the bandwidth correction in clause 4.3.10.1. | | |

Step 1:

Operation of the EUT shall be started, on the highest operating frequency as declared by the manufacturer, with the appropriate test signal.

The signal shape is recorded when stable and shall be below the spectrum mask Out Of Band for operating channel.

Step 2:

The test equipment shall be reconfigured as appropriate for the parameter shown below.

| Spectrum Analyser Setting | Value | Notes |
|---|---|---|
| Centre frequency | $f_{c_{low}}$ | The lowest Operating Frequency in the band |
| Span | $2 \times (500 \text{ kHz} + f_{c_{low}} - f_{low_OFB})$ | Ensures that the left most mask specification remains within the span |
| NOTE: f_{low_OFB} is the lower edge of the Operational Frequency Band. | | |

Operation of the EUT is restarted, with the appropriate test signal, on the lowest operating frequency as declared by the manufacturer.

If the equipment is using only one operating Frequency in the operational Frequency Band, measurement shall be performed the nominal operating frequency.

The signal shape is recorded when stable; and shall be below the spectrum mask for operating channel and the spectrum mask for operational frequency band.

Step 3:

The test equipment shall be reconfigured as appropriate for the parameter shown below.

| Spectrum Analyser Setting | Value | Notes |
|---|---|---|
| Centre frequency | $f_{c_{high}}$ | the highest Operating Frequency in the band |
| Span | $2 \times (500 \text{ kHz} + f_{high_OFB} - f_{c_{high}})$ | Ensures that the rightmost mask specification remains within the span |
| NOTE: f_{high_OFB} is the higher edge of the operational frequency Band. | | |

Operation of the EUT is restarted, with the appropriate test signal, on the highest Operating Frequency as declared by the manufacturer.

If the equipment is using only one Operating Frequency in the Operational Frequency Band, measurement shall be performed at the nominal Operating Frequency

The signal shape is recorded when stable and shall be below the spectrum mask for Out Of Band emissions for operating channel and for operational Frequency Band.

Step 4:

For frequency agile devices, the measurement shall be repeated in each Operational Frequency Band.

Step 5:

Where required (see clause 5.8.3.1 condition 1), the measurements in step 1 to step 5 shall be repeated under extreme test conditions.

11.4 Test Result

| Frequency Range | Test Result (dBm) | Max power limit (dBm) |
|---|----------------------|--------------------------|
| $f \leq \text{flow_OFB} - 400 \text{ kHz}$ | -45.43 | -36 |
| $\text{Flow_OFB} - 400 \text{ kHz} \leq f \leq \text{flow_OFB} - 200 \text{ kHz}$ | -41.50 | -36 |
| $\text{flow} - 200 \text{ kHz} \leq f < \text{flow_OFB}$ | -26.96 | See Figure 6 |
| $f = \text{flow_OFB}$ | -5.67 | 0 |
| $f = \text{fhigh_OFB}$ | -7.04 | 0 |
| $\text{Fhigh_OFB} < f \leq \text{fhigh_OFB} + 200 \text{ kHz}$ | -21.88 | See Figure 6 |
| $\text{Fhigh_OFB} + 200 \text{ kHz} \leq f \leq \text{fhigh_OFB} + 400 \text{ kHz}$ | -40.66 | -36 |
| $\text{Fhigh_OFB} + 400 \text{ kHz} \leq f$ | -42.63 | -36 |
| Remark: The limits decrease linearly with the logarithm . | | |

12. TX TRANSIENT

12.1 Block Diagram Of Test Setup

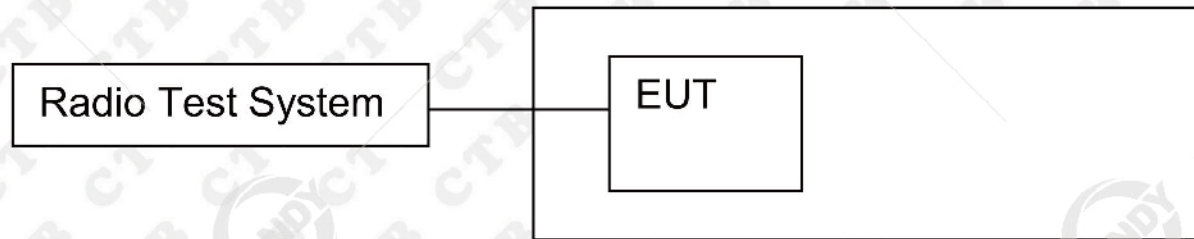

12.2 Limit

| Absolute offset from centre frequency | RBW _{REF} | Peak power limit applicable at measurement points |
|---------------------------------------|--------------------|---|
| ≤ 400 kHz | 1 kHz | 0 dBm |
| > 400 kHz | 1 kHz | -27 dBm |

12.3 Test procedure

The output of the EUT shall be connected to a spectrum analyser or equivalent measuring equipment.

The measurement shall be undertaken in zero span mode. The analyser's centre frequency shall be set to an offset from the operating centre frequency. These offset values and their corresponding RBW configurations are listed below.

Table 24: RBW for Transient Measurement

| Measurement points: offset from centre frequency | Analyser RBW | RBW _{REF} |
|--|--|--------------------|
| -0,5 x OCW - 3 kHz 0,5 x OCW + 3 kHz Not applicable for OCW < 25 kHz | 1 kHz | 1kHz |
| ±12,5 kHz or ±OCW whichever is the greater | Max (RBW pattern 1, 3, 10 kHz) ≤ Offset frequency/6 (see note) | 1 kHz |
| -0,5 x OCW - 400 kHz 0,5 x OCW + 400 kHz | 100 kHz | 1 kHz |
| -0,5 x OCW - 1 200 kHz 0,5 x OCW + 1 200 kHz | 300 kHz | 1 kHz |
| NOTE: Max (RBW pattern 1, 3, 10 kHz) means the maximum bandwidth that falls into the commonly implemented 1, 3, 10 kHz RBW filter bandwidth incremental pattern of spectrum analysers. EXAMPLE: If OCW is 25 kHz then the RBW value corresponding to one OCW offset frequency is 3 kHz. The rest of the analyser settings are listed in Table 25, and if OCW is 250 kHz then the RBW value corresponding to one OCW offset frequency is 30 kHz. | | |

Table 25: Parameters for Transient Measurement

| Spectrum Analyser Setting | Value | Notes |
|---|------------------|--|
| VBW/RBW | 10 | At higher RBW values VBW may be clipped to its maximum value |
| Sweep time | 500 ms | |
| RBW filter | Gaussian | |
| Trace Detector Function | RMS | |
| Trace Mode | Max hold | |
| Sweep points | 501 | |
| Measurement mode | Continuous sweep | |
| NOTE: The ratio between the number of sweep points and the sweep time shall be the same ratio as above if different number of sweep points is used. | | |

12.4 Test Result

| Absolute offset from centre frequency | Peak power limit applicable at measurement points | Test Value | Test results |
|---------------------------------------|---|------------|--------------|
| ≤ 400 kHz | 0 dBm | -12.17dBm | Pass |
| > 400 kHz | -27 dBm | -32.65dBm | Pass |

13. TX BEHAVIOUR UNDER LOW VOLTAGE CONDITIONS

13.1 Block Diagram Of Test Setup

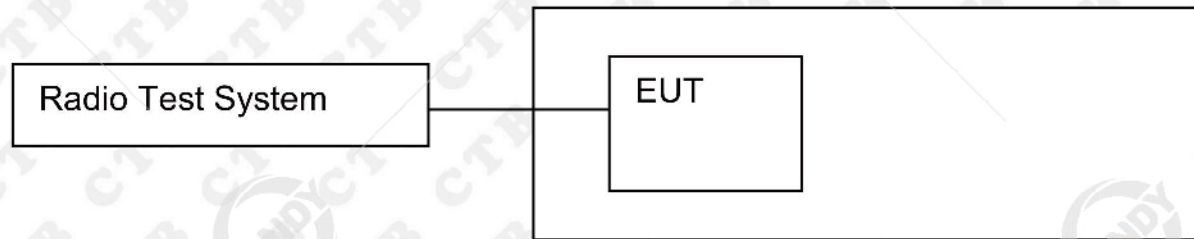

13.2 Limit

The equipment shall either:

- a) remain in the Operating Channel OC without exceeding any applicable limits (e.g. Duty Cycle); or
 - b) reduce its effective radiated power below the Spurious Emission limits without exceeding any applicable limits (e.g. Duty Cycle); or
 - c) shut down, (ceasing function);
- as the voltage falls below the manufacturers declared operating voltage.

13.3 Test procedure

Step 1:

Operation of the EUT shall be started, on Operating Frequency as declared by the manufacturer, with the appropriate test signal and with the EUT operating at nominal operating voltage.

The centre frequency of the transmitted signal shall be measured and noted.

Step 2:

The operating voltage shall be reduced by appropriate steps until the voltage reaches zero.

The centre frequency of the transmitted signal shall be measured and noted.

Any abnormal behaviour shall be noted.

13.4 Test Result

| Test Voltage | Test result |
|--------------|-------------|
| DC 12V | ok |
| DC 10.9V | ok |
| DC 9.6V | Not ok |
| DC 8.4V | Not ok |

14. RX BLOCKING

14.1 Block Diagram Of Test Setup

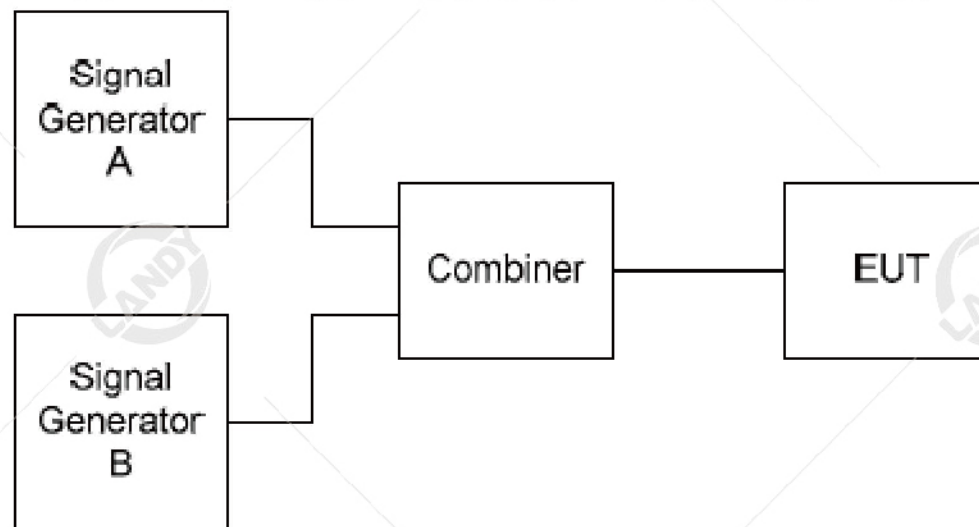

14.2 Limit

RX category 3

| Requirement | Limits |
|---|---------------------|
| | Receiver category 3 |
| Blocking at ± 2 MHz from OC edge f_{high} and f_{low} | ≥ -80 dBm |
| Blocking at ± 10 MHz from OC edge f_{high} and f_{low} | ≥ -60 dBm |
| Blocking at $\pm 5\%$ of Centre Frequency or 15 MHz, whichever is the greater | ≥ -60 dBm |

RX category 2

| Requirement | Limits |
|---|---------------------|
| | Receiver category 2 |
| Blocking at ± 2 MHz from OC edge f_{high} and f_{low} | ≥ -69 dBm |
| Blocking at ± 10 MHz from OC edge f_{high} and f_{low} | ≥ -44 dBm |
| Blocking at $\pm 5\%$ of Centre Frequency or 15 MHz, whichever is the greater | ≥ -44 dBm |

RX category 1.5

| Requirement | Limits |
|---|-----------------------|
| | Receiver category 1.5 |
| Blocking at ± 2 MHz from OC edge f_{high} and f_{low} | ≥ -43 dBm |
| Blocking at ± 10 MHz from OC edge f_{high} and f_{low} | ≥ -33 dBm |
| Blocking at $\pm 5\%$ of Centre Frequency or 15 MHz, whichever is the greater | ≥ -33 dBm |

RX category 1

| Requirement | Limits |
|---|---------------------|
| | Receiver category 1 |
| Blocking at ± 2 MHz from Centre Frequency | ≥ -20 dBm |
| Blocking at ± 10 MHz from Centre Frequency | ≥ -20 dBm |
| Blocking at $\pm 5\%$ of Centre Frequency or 15 MHz, whichever is the greater | ≥ -20 dBm |

14.3 Test procedure

Signal generator A shall be set to an appropriate modulated test signal at the operating frequency of the EUT receiver.

Signal generator B shall be unmodulated.

Measurements shall be carried out at frequencies of the unwanted signal at approximately the frequency(ies) offset(s) defined in technical requirement avoiding those frequencies at which spurious responses occur.

Additional

measurement points may be requested by technical requirements clause.

If several operational frequency bands are used by the equipment, at least one blocking measurement by bands has to be performed.

Step 1:

Signal generator B shall be powered off. Signal generator A shall be set to the minimum level which gives the wanted performance criterion of EUT or the reference level in Table 32, whichever is the higher. The output level of generator A shall then be increased by 3 dB unless otherwise specified in technical requirement.

Step 2:

Signal generator B is powered on and set to operate at the nominal operating frequency - offset frequency.

Signal generator B is then switched on and the signal amplitude is adjusted to the minimum level at which the wanted performance criterion is not achieved.

With signal generator B settings unchanged, the receiver shall be replaced with a suitable RF power measuring equipment. The power into the measuring equipment shall be measured and noted.

The blocking level is then the conducted power received from generator B at the EUT antenna connector.

This can either be measured on the antenna connector for conducted test or be calculated for radiated test (see clause C.5.4).

The blocking level shall be higher or equal to the blocking power level requested in the technical requirement clause.

Step 3:

The measurement in steps 1 to 3 shall be repeated with signal offsets at required frequencies.

Step 4:

The information shown in below Table shall be recorded in the test report for each measured signal level and unwanted signal offset.

| Value | Notes |
|---------------------|--|
| Operating Frequency | Nominal centre frequency of the receiver |
| Signal generator A | Power level of signal generator A |
| Blocking level | Power level of signal generator B |

14.4 Test Result

| Requirement (MHz) | Result (dBm) | Limit Receiver category 2 (dBm) |
|--|--------------|---------------------------------|
| Blocking at -2 MHz from OC edge f_{low} | -53.61 | ≥ -69 |
| Blocking at +2 MHz from OC edge f_{high} | -55.86 | ≥ -69 |
| Blocking at -10 MHz from OC edge f_{low} | -36.83 | ≥ -44 |
| Blocking at +10 MHz from OC edge f_{high} | -36.83 | ≥ -44 |
| Blocking at -5 % of Centre Frequency edge f_{low} | -33.55 | ≥ -44 |
| Blocking at +5 % of Centre Frequency edge f_{high} | -34.34 | ≥ -44 |

15. EUT PHOTOGRAPHS

Refer to Report No. CTB25090108101RE03 for EUT external and internal photos.

16. EUT TEST SETUP PHOTOGRAPHS

Radiated emissions above 1G

**※※※※※ END OF REPORT ※※※※※**